

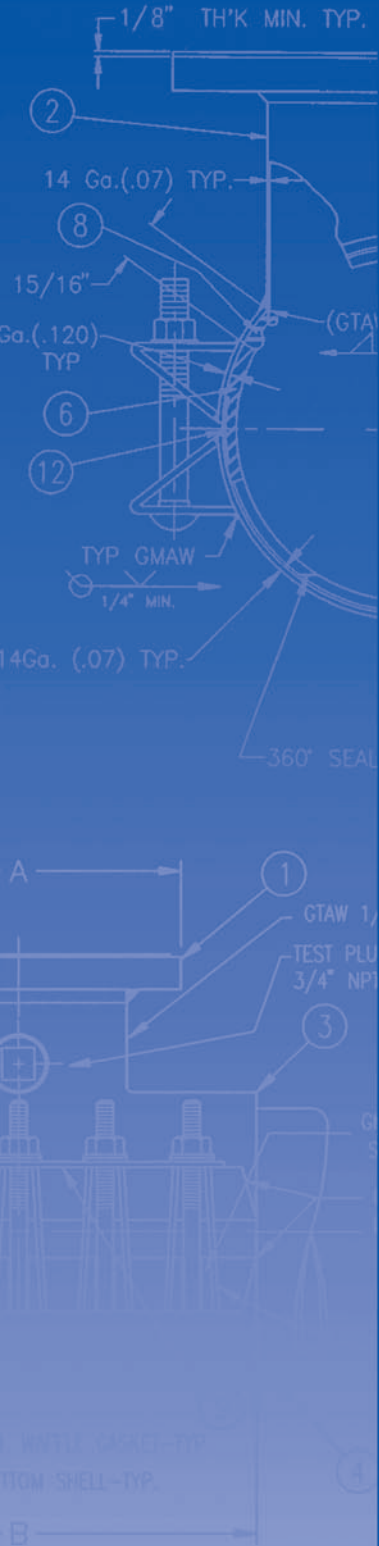

PIPE REPAIR PRODUCTS REPAIR CLAMPS

“The Standard
of Excellence in
the Industry”



1213 BADGER STREET • YORKVILLE, ILLINOIS 60560
(630) 553-0840 • (800) 426-4301 • FAX (630) 553-0181
www.cascademfg.com

CASCADE...PIPE REPAIR MADE QUICK & EASY

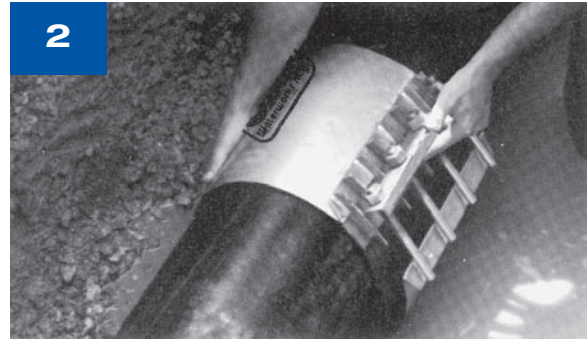

Wrap clamp around pipe. Bring together using locking washer plate.

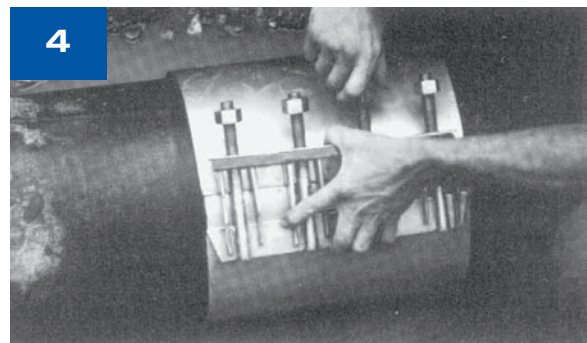
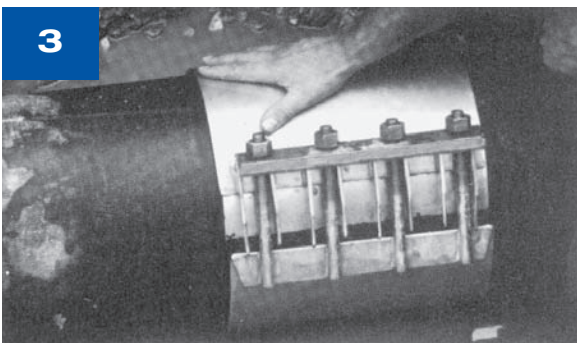

Lock in place. Squeeze the lugs together and spin the nuts down.

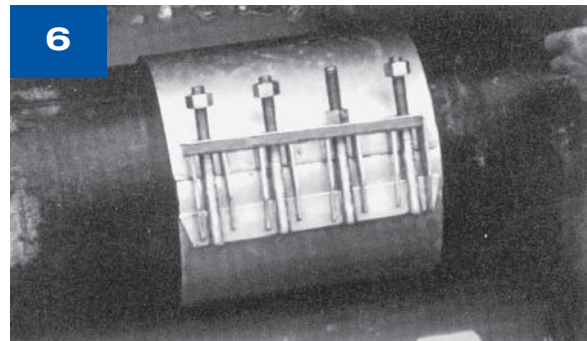
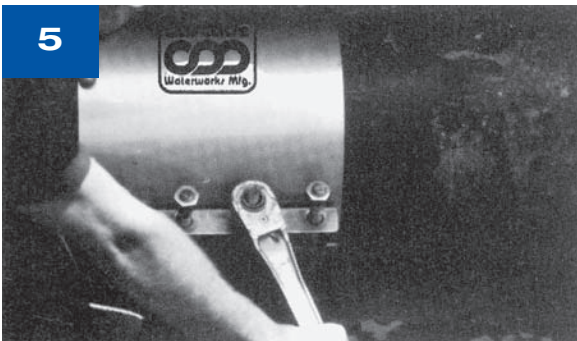

Tighten the nuts evenly working from the outside to the inside with a wrench. Detailed instructions are attached to each clamp.

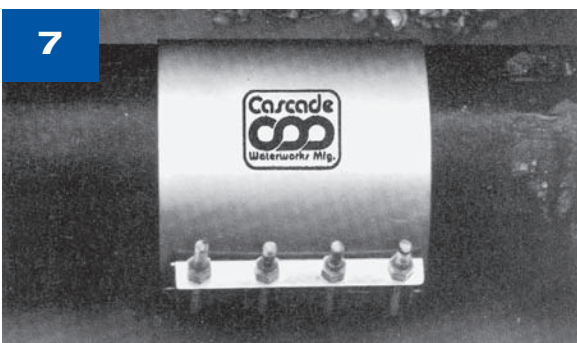

You have just made a permanent repair.

Take a good look at the clamp before you bury it. It's the last time you'll ever see it!



Produced for Logan Diving, Inc. for installation on 48" HDPE with spiraling crack. HDPE line is outfall from a Jacksonville, FL. treatment plant in the Ortega River.

CASCADE designs and produces repair clamps for all kinds of special needs, including very large diameter, varying O.D. sections, high temperatures, concrete joints, and cracked iron pipe Bell joints.

CALL CASCADE WITH YOUR SPECIAL NEEDS

MATERIAL SPECIFICATIONS

CR1

WASHER

PLATE: T304 SST
Locks into position for easy tightening of nuts.

FINGER LUGS:

T304 SST MIG welded to receiver bar. Leading edge is rounded to permit locking washer plate to slide into position easily.

SHELL: T304 SST

STUDS: 18-8 SST, 5/8"-11 NC rolled thread. Studs are MIG welded to bolt bar.

NUTS: 18-8 SST, 5/8"-11 heavy hex, Xylan coated

STUD & RECEIVER BARS: T304 SST TIG welded to shell.

GASKET: SBR formulated for water service with antioxidant/antiozonant agents to increase shelf life.

ARMOR: T304 SST

OUTLET: 18-8 SST TIG welded to shell.

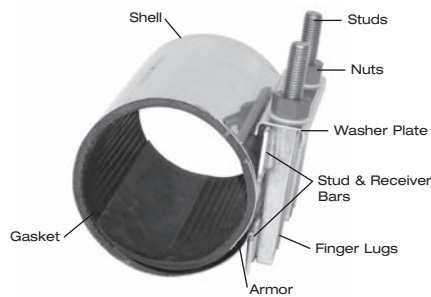

CDR1

LUGS: Ductile Iron ASTM A536 Grade 65-45-12. Designed for ease of installation.

LUG SHELL & JOINT:

Joint connection designed for maximum torquing.

SHELL: T304 SST

BOLTS: High strength low alloy steel 5/8" NC. T304 SST available.

NUTS: High strength low alloy steel. T304 SST available.

GASKET: SBR formulated for water service with antioxidant/antiozonant agents to increase shelf life. (Also available in EPDM.)

ARMOR: Stainless Steel T304.

OUTLET: Stainless steel 18-8 TIG welded to shell.

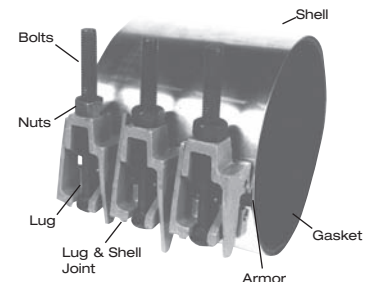

Clamps are also available with T316 Stainless Steel. CDR fasteners are also available in T304 or T316. All weldments are fully passivated in accordance with ASTM A380.

* Repair Clamps do not provide restraint against lateral movement of pipe.



To Order: Determine desired range and length, then select corresponding catalog number.

Note: Other ranges and lengths not listed are available upon request. For higher pressures, clamp length should be equal to or in excess of pipe O.D.

Conductivity Strips available upon request.



Nominal Pipe Size (Inches)	Clamp O.D. Range (Inches)	Catalog Number	Approximate Shipping Weight (lbs.) per length							
			6"	8"	10"	12"	16"	20"	24"	30"
2	2.32-2.63	CR1 - 263 - Length	4	5	6	7	10	—	—	—
2 1/4	2.57-2.87	CR1 - 287 - Length	4	5	6	7	10	—	—	—
2 1/4-2 1/2	2.70-3.00	CR1 - 300 - Length	4	5	6	7	10	—	—	—
3	2.95-3.25	CR1 - 325 - Length	4	5	6	8	10	—	—	—
	3.40-3.70	CR1 - 370 - Length	4	6	7	9	12	—	—	—
3 & 4	3.71-4.00	CR1 - 400 - Length	—	6	7	9	12	—	—	—
4	4.45-4.75	CR1 - 475 - Length	—	7	8	10	13	17	—	—
	4.75-5.15	CR1 - 515 - Length	—	7	8	10	13	17	20	25
4 & 5	4.95-5.35	CR1 - 535 - Length	—	7	8	11	14	18	20	25
	5.20-5.60	CR1 - 560 - Length	—	7	8	11	14	18	20	26
6	5.95-6.35	CR1 - 635 - Length	—	8	10	11	15	19	22	30
	6.55-6.95	CR1 - 695 - Length	—	8	10	11	15	19	23	30
	6.84-7.24	CR1 - 724 - Length	—	9	11	12	16	20	24	32
	7.05-7.45	CR1 - 745 - Length	—	9	11	12	17	21	25	32
8	7.45-7.85	CR1 - 785 - Length	—	9	11	13	18	22	26	34
	7.95-8.35	CR1 - 835 - Length	—	9	12	14	19	23	28	35
	8.59-8.99	CR1 - 899 - Length	—	9	12	14	19	23	28	35
	9.00-9.40	CR1 - 940 - Length	—	10	13	14	20	24	29	37
8 & 10	9.30-9.70	CR1 - 970 - Length	—	10	13	15	20	25	31	38
	9.75-10.15	CR1 - 1015 - Length	—	11	13	16	21	27	32	40
10	10.65-11.05	CR1 - 1105 - Length	—	11	14	17	22	28	34	42
	11.04-11.44	CR1 - 1144 - Length	—	12	14	17	22	29	36	44
	11.35-11.75	CR1 - 1175 - Length	—	12	14	17	23	30	37	45
	11.75-12.15	CR1 - 1215 - Length	—	13	15	18	24	30	37	46
12	11.95-12.35	CR1 - 1235 - Length	—	13	15	18	26	31	38	47
	12.65-13.05	CR1 - 1305 - Length	—	14	16	19	28	32	38	48
	13.10-13.50	CR1 - 1350 - Length	—	15	17	20	28	32	38	48
12 & 14	13.40-13.80	CR1 - 1380 - Length	—	15	18	21	29	33	39	48
	13.70-14.10	CR1 - 1410 - Length	—	16	18	21	29	33	39	48
	14.00-14.40	CR1 - 1440 - Length	—	16	19	22	29	35	41	52
Number of Studs			2	2	3	3	4	5	6	8

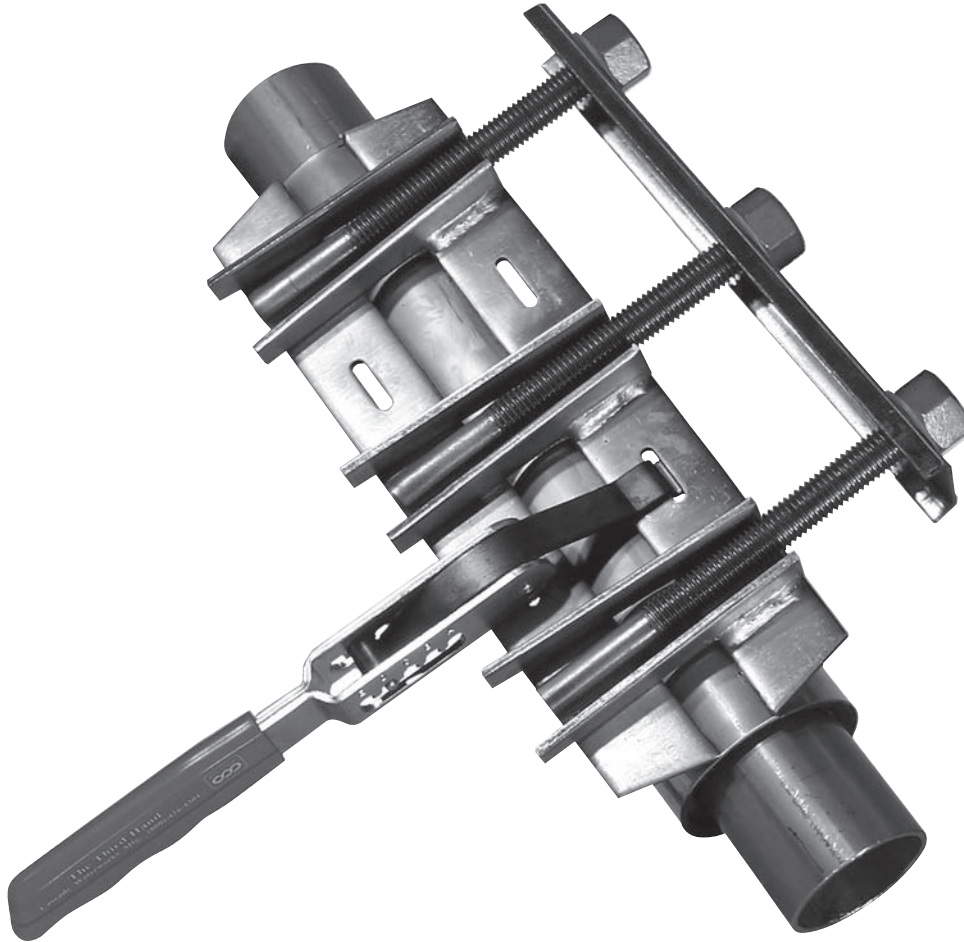

FEATURES & BENEFITS



- Easier to attach Repair Clamps to pipe (especially smaller Pipe ODs)
- Safely attach Repair Clamps to Pipe — Clamp is held in place while the nuts are tightened
- Easier to slide Repair Clamp into place over leak
- Adjustability for all:
 - CR Series Repair Clamps & (CR1, CR2, CR2-SR, CR3)
 - CRT Series Tapped Repair Clamps (CRT1, CRT2, CRT2-SR, CRT3)
- Compact tool size
- Materials resistant to wear
- Saves time during installation
- More consistent installations
- Able to handle harsh environments
- Designed for Left-handed or Right-handed use
- Easy to use
- Lifetime warranty
- Patent 7,364,202 B1 & 7,314,236 B2

Catalog Number: CR1-TOOL

STYLE CR2

DOUBLE SECTION - WIDE RANGE



To Order: Determine desired range and length, then select corresponding catalog number.

Note: Other ranges and lengths not listed are available upon request. For higher pressures, clamp length should be equal to or in excess of pipe O.D.

Conductivity Strips available upon request.



Nominal Pipe Size (Inches)	Clamp O.D. Range (Inches)	Catalog Number	Approximate Shipping Weight (lbs.) per length						
			8"	10"	12"	16"	20"	24"	30"
4	4.44-5.26	CR2 - 526 - Length	12	14	17	24	28	34	42
	4.75-5.57	CR2 - 557 - Length	13	15	18	26	30	39	45
6	6.56-7.36	CR2 - 736 - Length	14	18	21	28	34	44	53
	6.84-7.64	CR2 - 764 - Length	15	19	23	29	36	46	56
8	8.60-9.40	CR2 - 940 - Length	17	21	25	30	38	48	59
	8.99-9.79	CR2 - 979 - Length	17	21	25	31	38	48	59
10	10.70-11.50	CR2 - 1150 - Length	22	25	27	33	40	49	60
	11.05-11.85	CR2 - 1185 - Length	22	25	27	33	40	49	60
	11.40-12.20	CR2 - 1220 - Length	23	26	28	35	41	50	61
12	12.70-13.50	CR2 - 1350 - Length	24	26	29	36	42	51	63
	13.15-13.95	CR2 - 1395 - Length	25	27	30	37	43	52	63
	13.60-14.40	CR2 - 1440 - Length	25	27	31	39	44	53	64
14	13.85-14.65	CR2 - 1465 - Length	25	27	32	40	45	55	66
	14.38-15.18	CR2 - 1518 - Length	26	28	33	41	46	57	69
	15.07-15.87	CR2 - 1587 - Length	27	29	34	42	47	58	71
16	15.92-16.67	CR2 - 1667 - Length	28	31	35	43	50	64	74
	16.56-17.31	CR2 - 1731 - Length	30	32	36	44	51	64	77
	17.15-17.90	CR2 - 1790 - Length	31	34	36	44	55	71	84
18	17.82-18.57	CR2 - 1857 - Length	32	35	38	46	56	73	86
	18.46-19.21	CR2 - 1921 - Length	33	36	39	47	58	74	87
	19.23-19.98	CR2 - 1998 - Length	34	38	40	48	60	76	89
20	19.90-20.65	CR2 - 2065 - Length	35	38	41	49	61	80	93
	20.70-21.45	CR2 - 2145 - Length	36	39	43	51	63	83	101
	21.52-22.27	CR2 - 2227 - Length	37	40	45	53	67	88	101
	22.12-22.87	CR2 - 2287 - Length	38	41	47	55	70	92	105
	22.90-23.65	CR2 - 2365 - Length	39	43	49	58	75	98	111
Number of Studs			4	6	6	8	10	12	16

CR2-SR

DOUBLE SECTION - SUPER RANGE

8	8.60-9.80	CR2 - SR - 980 - Length	18	22	27	34	42	52	64
	10.70-11.90	CR2 - SR - 1190 - Length	23	27	31	40	46	58	72
10	11.05-12.25	CR2 - SR - 1225 - Length	23	27	31	40	46	58	72
	12.70-13.90	CR2 - SR - 1390 - Length	23	27	31	40	46	58	72
12-14	13.15-14.35	CR2 - SR - 1435 - Length	26	29	36	45	57	74	84
	13.65-14.85	CR2 - SR - 1485 - Length	26	29	36	45	57	74	84
14-16	14.45-15.65	CR2 - SR - 1565 - Length	26	29	36	45	57	74	84
	14.85-16.05	CR2 - SR - 1605 - Length	28	32	39	48	61	81	94
	15.92-17.12	CR2 - SR - 1712 - Length	28	32	35	48	61	81	94
16-18	17.15-18.35	CR2 - SR - 1835 - Length	33	37	43	52	65	85	101
	18.46-19.66	CR2 - SR - 1966 - Length	33	37	43	52	65	85	101
18-20	19.45-20.65	CR2 - SR - 2065 - Length	39	42	48	57	73	95	107
	21.50-22.70	CR2 - SR - 2270 - Length	39	42	48	57	73	95	107

STYLE CR3

TRIPLE SECTION - EXTENDED RANGE



To Order: Determine desired range and length, then select corresponding catalog number.

Note: Other ranges and lengths not listed are available upon request. For higher pressures, clamp length should be equal to or in excess of pipe O.D.

Conductivity Strips available upon request.



Clamp O.D. Range (Inches)	Catalog Number	Approximate Shipping Weight (lbs.) per length					
		10"	12"	16"	20"	24"	30"
11.04-12.24	CR3 - 1224 - Length	26	31	41	53	61	82
13.14-14.34	CR3 - 1434 - Length	28	33	43	54	65	84
13.65-14.85	CR3 - 1485 - Length	29	34	44	55	66	86
14.85-16.05	CR3 - 1605 - Length	30	35	45	56	67	88
15.92-17.12	CR3 - 1712 - Length	32	37	47	58	70	94
17.15-18.35	CR3 - 1835 - Length	33	38	48	59	72	96
18.46-19.66	CR3 - 1966 - Length	34	39	49	62	75	98
19.45-20.65	CR3 - 2065 - Length	36	40	53	67	80	102
21.52-22.72	CR3 - 2272 - Length	—	42	63	72	84	107
23.28-24.48	CR3 - 2448 - Length	—	43	64	77	87	117
24.38-25.58	CR3 - 2558 - Length	—	45	65	78	92	120
25.70-26.90	CR3 - 2690 - Length	—	47	66	80	95	123
26.48-27.68	CR3 - 2768 - Length	—	48	66	82	97	127
27.65-28.85	CR3 - 2885 - Length	—	50	67	85	102	130
28.73-29.93	CR3 - 2993 - Length	—	52	69	88	106	136
29.62-30.82	CR3 - 3082 - Length	—	51	70	78	108	138
31.22-32.42	CR3 - 3242 - Length	—	54	71	90	110	140
Number of Studs		9	9	12	15	18	24

STYLE CRT & CDRT

TAPPED REPAIR CLAMPS

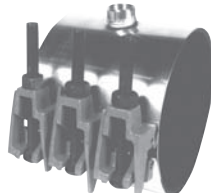
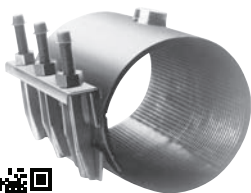

All CR1, CR2, CR2-SR, CR3, and CDR1, CDR2, and CDR3 repair clamps are available with tapped outlets. Outlets are T304 stainless steel TIG welded to the clamp and fully passivated, in accordance with ASTM A380.

To Order:

Select size, length and style of clamp. Select type and size of thread for outlet. Add list price for outlet to list price for clamp. Insert the letter "T" into the catalog number and indicate tap size and type style at the end. Consult catalog or factory for specification or application information.

Example:

A single band clamp for 6" D.I.P. - 12" long with a 3/4" CC Outlet = CRT1-724-12-3/4CC



Tap Size Available	Type of Threads Available
3/4"	IP or CC
1"	IP or CC
1 1/4"	IP or CC
1 1/2"	IP or CC
2"	IP or CC

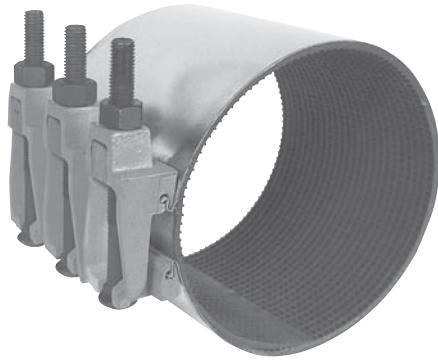

Note: Other ranges and widths not listed may be available upon request. For higher pressures, clamp width should be equal or exceed pipe O.D. Conductivity strips are available.



Nominal Pipe Size (Inches)	Clamp O.D. Range (Inches)	Catalog Number	Approximate Shipping Weight (lbs.) per length										
			5"	7.5"	10"	12.5"	15"	20"	25"	30"			
2	2.32-2.63	CDR1 - 263 - Length	7	9	13	16	19	<i>Consult Factory</i>					
2 1/4	2.57-2.87	CDR1 - 287 - Length	7	9	13	16	19						
2 1/4-2 1/2	2.70-3.00	CDR1 - 300 - Length	7	9	13	16	19						
3	2.95-3.25	CDR1 - 325 - Length	7	11	14	18	21						
	3.40-3.70	CDR1 - 370 - Length	7	11	14	18	21						
3 & 4	3.71-4.00	CDR1 - 400 - Length	7	11	14	18	21				<i>Consult Factory</i>		
4	4.45-4.75	CDR1 - 475 - Length	8	11	14	18	21						
	4.75-5.15	CDR1 - 515 - Length	8	11	14	19	23	30	38	45			
4 & 5	4.95-5.35	CDR1 - 535 - Length	8	11	15	19	23	30	38	45			
	5.20-5.60	CDR1 - 560 - Length	8	11	16	19	23	31	39	46			
6	5.95-6.35	CDR1 - 635 - Length	9	12	16	20	23	31	39	46			
	6.55-6.95	CDR1 - 695 - Length	9	12	17	20	24	33	40	47			
6	6.84-7.24	CDR1 - 724 - Length	9	12	17	20	24	33	40	47			
	7.05-7.45	CDR1 - 745 - Length	9	12	17	21	25	33	41	49			
8	7.45-7.85	CDR1 - 785 - Length	10	12	17	21	25	34	41	49			
	7.95-8.35	CDR1 - 835 - Length	10	12	17	21	25	34	42	51			
8	8.59-8.99	CDR1 - 899 - Length	11	13	18	22	26	35	44	52			
	9.00-9.40	CDR1 - 940 - Length	11	13	18	22	26	36	45	52			
8 & 10	9.30-9.70	CDR1 - 970 - Length	11	13	18	22	26	36	45	54			
	9.75-10.15	CDR1 - 1015 - Length	11	13	18	23	27	36	45	54			
10	10.65-11.05	CDR1 - 1105 - Length	-	14	20	24	29	38	47	56			
	11.04-11.44	CDR1 - 1144 - Length	-	14	20	24	30	39	48	58			
	11.35-11.75	CDR1 - 1175 - Length	-	15	20	25	30	40	49	61			
	11.75-12.15	CDR1 - 1215 - Length	-	15	21	26	30	40	49	61			
	11.95-12.35	CDR1 - 1235 - Length	-	15	21	26	31	41	50	62			
12	12.65-13.05	CDR1 - 1305 - Length	-	16	21	27	31	41	52	63			
	13.10-13.50	CDR1 - 1350 - Length	-	17	22	27	31	42	52	64			
12 & 14	13.40-13.80	CDR1 - 1380 - Length	-	18	22	28	34	44	55	68			
	13.70-14.10	CDR1 - 1410 - Length	-	18	23	29	34	46	59	69			
	14.00-14.40	CDR1 - 1440 - Length	-	19	24	30	36	47	61	71			
Number of Bolts			2	3	4	5	6	8	10	12			

STYLE CDR2

DOUBLE SECTION - WIDE RANGE

Nominal Pipe Size (Inches)	Clamp O.D. Range (Inches)	Catalog Number	Approximate Shipping Weight (lbs.) per length					
			7.5"	10"	12.5"	15"	20"	30"
4	4.44-5.26	CDR2 - 526 - Length	19	26	32	41	52	78
	4.75-5.57	CDR2 - 557 - Length	19	26	32	41	52	78
6	6.58-7.36	CDR2 - 736 - Length	21	28	35	44	53	81
	6.84-7.64	CDR2 - 764 - Length	21	28	35	45	55	83
8	8.99-9.79	CDR2 - 979 - Length	22	30	37	48	59	89
10	10.70-11.50	CDR2 - 1150 - Length	24	31	39	49	60	90
	11.06-11.65	CDR2 - 1165 - Length	25	31	40	50	63	94
	11.40-12.20	CDR2 - 1220 - Length	28	32	41	51	64	96
12	12.70-13.50	CDR2 - 1350 - Length	29	33	43	52	66	97
	13.15-13.95	CDR2 - 1395 - Length	29	33	46	53	66	99
	13.60-14.40	CDR2 - 1440 - Length	30	35	47	53	67	101
	13.85-14.65	CDR2 - 1465 - Length	32	36	49	54	71	102
14	14.38-15.18	CDR2 - 1518 - Length	-	36	-	58	73	111
	15.07-15.87	CDR2 - 1587 - Length	-	38	-	59	75	113
16	15.92-16.67	CDR2 - 1667 - Length	-	38	-	60	75	114
	16.56-17.31	CDR2 - 1731 - Length	-	39	-	62	76	116
	17.15-17.90	CDR2 - 1790 - Length	-	40	-	63	78	118
	17.82-18.62	CDR2 - 1862 - Length	-	40	-	64	78	119
18	18.41-19.21	CDR2 - 1921 - Length	-	41	-	65	79	120
	19.23-19.98	CDR2 - 1998 - Length	-	41	-	65	80	122
	19.90-20.70	CDR2 - 2070 - Length	-	41	-	66	81	124
20	20.70-21.45	CDR2 - 2145 - Length	-	43	-	68	83	125
	21.52-22.27	CDR2 - 2227 - Length	-	45	-	69	86	130
	22.12-22.87	CDR2 - 2287 - Length	-	46	-	69	88	134
	22.90-23.65	CDR2 - 2365 - Length	-	48	-	69	92	139
Number of Bolts			6	8	10	12	16	24

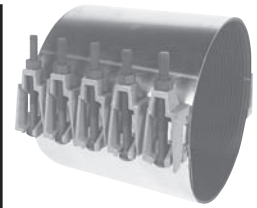

STYLE CDR3

TRIPLE SECTION - EXTENDED RANGE

Clamp O.D. Range (Inches)	Catalog Number	Approximate Shipping Weight (lbs.) per length					
		10"	12.5"	15"	20"	25"	30"
11.04-12.24	CDR3 - 1224 - Length	47	56	72	96	120	152
13.14-14.34	CDR3 - 1434 - Length	50	63	76	100	128	157
13.65-14.85	CDR3 - 1485 - Length	54	67	81	106	134	160
14.85-16.05	CDR3 - 1605 - Length	57	70	85	108	136	162
15.92-17.12	CDR3 - 1712 - Length	60	79	90	112	139	165
17.15-18.35	CDR3 - 1835 - Length	62	81	92	116	143	167
18.46-19.66	CDR3 - 1966 - Length	66	83	96	119	146	170
19.45-20.85	CDR3 - 2085 - Length	69	89	101	123	150	172
21.52-22.72	CDR3 - 2272 - Length	71	90	104	126	153	175
23.28-24.48	CDR3 - 2448 - Length	73	92	108	128	156	180
24.38-25.58	CDR3 - 2558 - Length	-	93	109	131	158	184
25.70-26.90	CDR3 - 2690 - Length	-	95	110	133	161	189
26.48-27.68	CDR3 - 2768 - Length	-	97	113	164	164	190
27.65-28.85	CDR3 - 2885 - Length	-	99	115	140	166	196
28.73-29.93	CDR3 - 2993 - Length	-	100	117	144	170	198
29.62-30.82	CDR3 - 3082 - Length	-	102	120	147	175	200
31.22-32.42	CDR3 - 3242 - Length	-	113	139	160	188	202
Number of Bolts		12	15	18	24	30	36

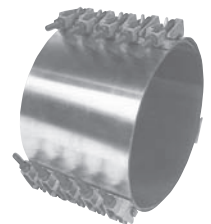

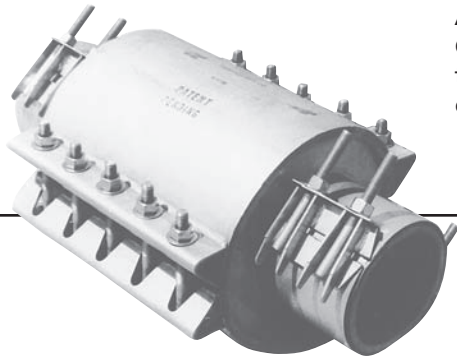

A Cascade Invention Patent No. 5,288,108.

Quick and complete repair of cracked bell without cutting pipe and shutting down line. Pipes can be repaired under pressure, eliminating costly chlorination and notification of boil water notices.

FEATURES

- Fully encloses any type of Bell Joint or coupling
- All Stainless Steel, the ultimate corrosion protection
- Custom designed to fit any size diameter



MATERIAL SPECIFICATIONS

Shell / Lugs / Retaining Clamps: T304 SST

Fasteners: T304 SST 5/8-11 NC, Rolled Thread; Xylan Coated Heavy Hex Nut

Washers/Washer Plate: T304 SST

Gaskets: Virgin SBR

Normal Pipe Size	Catalog Number	Approx. Weight (lbs.)
		(Specify Joint Type)
4	CRBJ-0400	135
	CRBJ-0480	
	CRBJ-0510	
6	CRBJ-0600	190
	CRBJ-0690	
	CRBJ-0710	
8	CRBJ-0800	235
	CRBJ-0905	
	CRBJ-0940	
10	CRBJ-1000	300
	CRBJ-1110	
	CRBJ-1140	
12	CRBJ-1200	365
	CRBJ-1320	
	CRBJ-1350	
14	CRBJ-1400	420
	CRBJ-1530	
	CRBJ-1565	
16	CRBJ-1600	485
	CRBJ-1740	
	CRBJ-1780	
18	CRBJ-1950	545
	CRBJ-1992	
20	CRBJ-2160	620
	CRBJ-2206	

NOTE: Due to the variety of Bells in service, please obtain precise dimensions. It is recommended that you consult Cascade Waterworks once you have obtained all pertinent details regarding the bell crack.

TO ORDER: Determine actual pipe O.D., Bell Type, Bell O.D., length of crack in bell, etc. Consult with factory for proper selection.

Cascade's Bell Joint Repair Sleeve (CRBJ) is designed to seal cracked bells when no other means of repair is feasible, and a temporary shut-down is not possible (such as with hospital service). This labor intensive sleeve is not meant as a means of sealing a failed gasket, where other repair options are available. Be prepared for extended lead times on this highly specialized product.

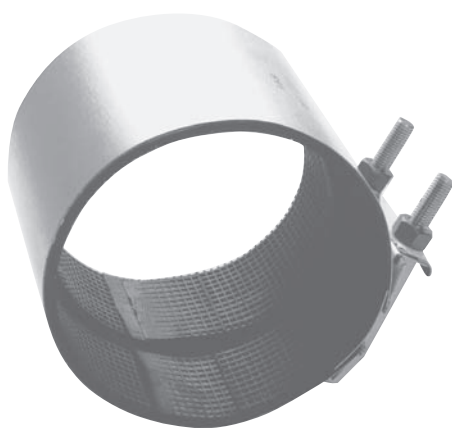

For easy repair of leaking solvent welded PVC pipe joints.

To Order: Determine desired range and length, then select corresponding catalog number.

Consult Factory on all pricing requests

Nominal Pipe Size (Inches)	Clamp O.D. Range (Inches)	Catalog Number	Approximate Shipping Weight (lbs.) per length			
			6"	8"	12"	16"
2	2.38	CCLC - 238 - Length	5	6	7	9
2 1/2	2.88	CCLC - 288 - Length	5	6	7	9
3	3.50	CCLC - 350 - Length	5	6	7	9
4	4.50	CCLC - 450 - Length	6	7	8	10
6	6.63	CCLC - 663 - Length	7	8	9	11
8	8.63	CCLC - 863 - Length	8	9	10	12

NOTE: Standard CCLC designed for Class 160 and SDR 26 PVC solvent weld collars.

WARRANTY

Cascade Waterworks Mfg. Co. warrants its product(s) for one year from the date of shipment to be free of defects in material or workmanship. Cascade will repair or replace this product if found to be defective within the warranty period, provided that the buyer submits his claim in writing and delivers the original claimed defective product in its entirety, freight prepaid to Cascade Waterworks Mfg. Co., 1213 Badger Street, Yorkville, IL, 60560 for inspection within 30 days. Any written notice and/or product shall be sent directly to Cascade unless otherwise instructed. Sending these to a manufacturer's representative or any other agent prior to Cascade's review will void all warranties. Cascade will not be liable nor responsible for any

loss, damage or injury to any persons or property directly or indirectly arising from the use or inability to use this product. The user shall determine the suitability of the product for its intended use prior to any application and said user assumes all risks in connection with the use of this product. No claims for labor or damage will be allowed. The foregoing warranties and remedies are exclusive and in lieu of all others, whether written, oral, or implied. Buyer must advise Cascade within 30 days of discovery of the alleged defect or the claim will be barred. Upon the products' purchase from Cascade Waterworks Mfg. Co., or any of its Agents, the purchaser agrees to all of the above terms of warranty.

05/15

