

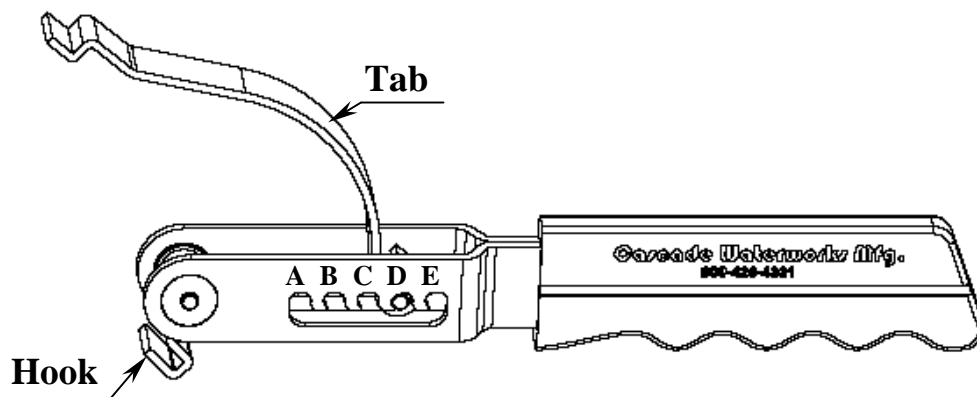

"THE STANDARD OF EXCELLENCE IN THE INDUSTRY"

Instructions for the Third Hand Tool

For the Third Hand Tool, the top finger (**Tab**) is longer than the bottom finger (**Hook**). (See drawing below.)



- ◆ Insert the Tab into the Slot in the Repair Clamp's Receiver Bar Slot.
- ◆ Place the Hook on the outside edge of the Bolt Bar.
- ◆ Adjust the Tab's pin to be in Slot "C".
- ◆ Pull down the Third Hand Tool. The Third Hand should lock into place.

If the Third Hand is too loose, open & move the Tab's pin back 1 notch toward "E", try again.

If the Third Hand is too tight, open & move the Tab's pin forward 1 notch toward "A", try again.

- ◆ Tighten Nuts on Repair Clamp as instructed.
- ◆ Lift the handle to Unclamp &
Remove The Third Hand Tool.

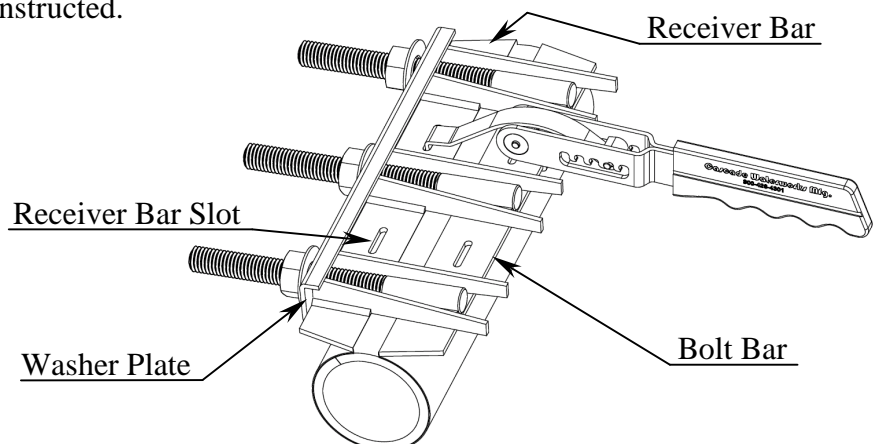

Cascade Waterworks Manufacturing Company

1213 Badger Street • Yorkville, IL 60560 • (630) 553-0840 • (800) 426-4301 • FAX (630) 553-0181

www.cascademfg.com